

# COIL SPRING COMPRESSOR

## KL-0021 For WISHBONES PAT.

This tool is genuinely used by Mercedes-Benz. It contains numerous patented safety mechanisms, and promotes fast, safe work (work time is reduced by anywhere from 1.5 to 2 hours!).

- Ideal for Mercedes-Benz cars!
- New safety interlock system used!
- (3-point hook type)
- Automatic interlock system!
- (Automatically becomes free at work boundary)
- Work can be done without removing and re-installing various suspension components.

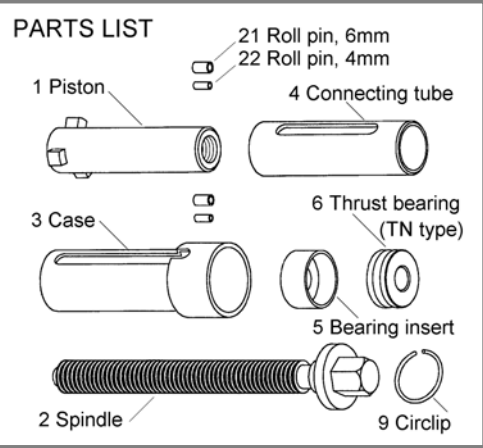
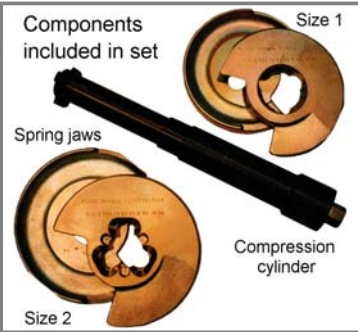

### TECHNICAL DATA & OPTIONAL PARTS

Work area (stroke): ~ 320 mm  
 Spring jaw size  
 (outer diameters of applicable springs):  
 Size 1: 120 ~ 130      Size 2: 140 ~ 150  
 Max. safe weighting: 26,000 N



### OPTIONS

KL-0021-OP: Optional collar  
 (comes as set)

When using with Crown or Cedric (430) cars, an optional collar (sold separately) should be used.

